



*Dave Whites*

**SitePro™**

**OPERATING MANUAL**

CONSIGNES DE FONCTIONNEMENT

INSTRUCCIONES DE FUNCIONAMIENTO



model | modelo

**KS3P, KS5P, KS5PG**

POINT LASERS



**IMPORTANT:**

Read Before Using

**IMPORTANT:**

Lire avant usage

**IMPORTANTE:**

Leer antes de usar

# KEEP IT SIMPLE WITH THE KS-SERIES

by SitePro

## KS3P / KS5P / KS5PG

### POINT LASER

Congratulations! You've purchased a SitePro laser that is simple to use with one-button operation for precise and accuracy leveling, plumb, layout and squaring.

The purpose of this user's guide is to acquaint you with the laser tool, its components, safety, proper care and handling.

All laser tools are adjusted and calibrated when they are shipped from the factory. It is the customer's responsibility to check and to ensure instruments are adjusted prior to using.

SitePro is not responsible for errors caused by laser tools that are out of adjustment. Contact your local SitePro distributor or dealer for information on the nearest facility to check if your instrument is properly adjusted. Contact Dave White's SitePro for questions and help locating your local dealer.

All specifications are subject to change without notice.

**SAFETY INSTRUCTION**

Page 17





## KS 3P 3-Point Laser

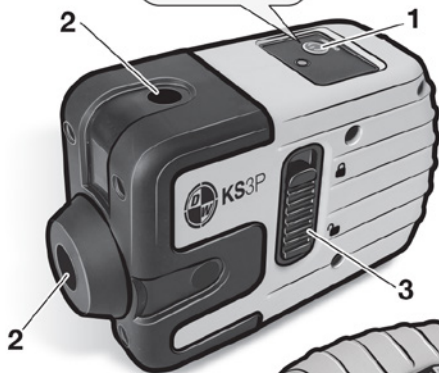



## KS 5P, KS 5PG

5-Point Laser

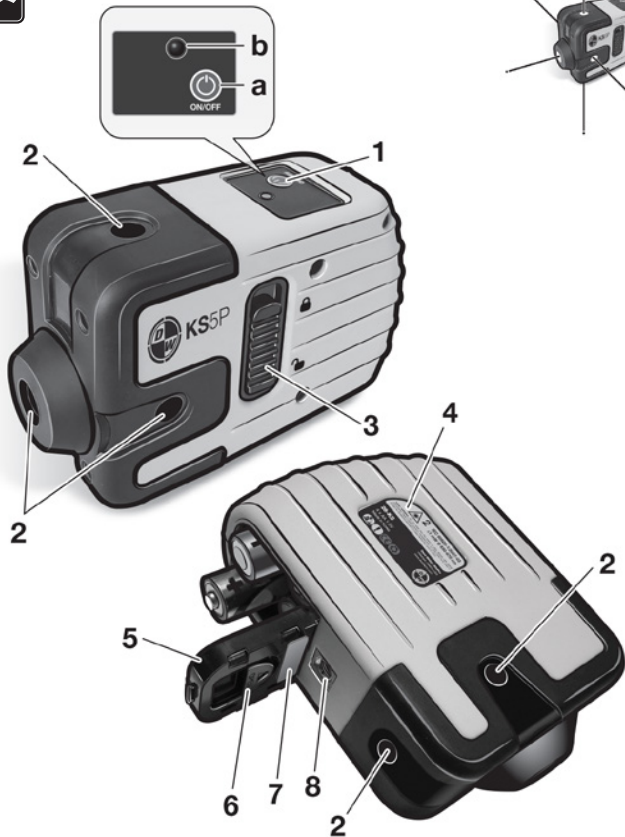



## UMP1 Multi-Mounting Device

KS 3P Shown  
mounted on UMP1

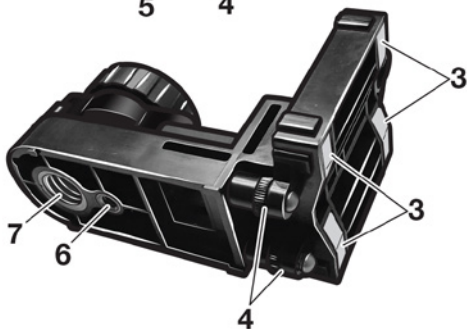
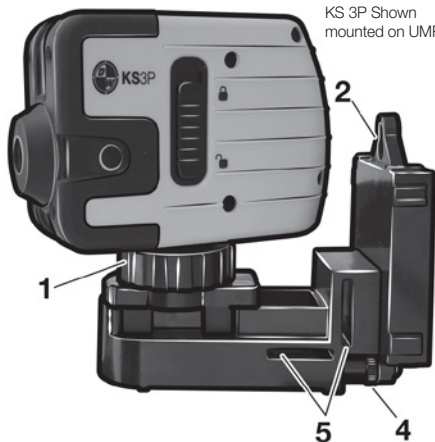

## INTENDED USE

This laser tool projects a laser points:

- The KS 3P projects three points: one point up, one down and one horizontal point 90 degrees to plumb points. Ideal for transferring points from floor to ceiling, leveling, plumb, and simple layout.
- The KS 5P projects five points: one point up, one down and three horizontal points 90 degrees to each other. Ideal for transferring points, leveling, plumb, layout and squaring.

## FEATURES AT A GLANCE

The numbering of the product features shown refers to the illustration of the tool on page 3 and 4.

1. Control Keypad
- 1a. Power ON/OFF Button
- 1b. Battery/Operating Mode Indicator
2. Exit opening for laser points
3. Safety Lock / Automatic Leveling Switch
4. Safety Label and Nameplate
5. Battery Compartment Door
6. Latch Release
7. Serial Number
8. 1/4-20 Tripod Mounting Thread

## PREPARATIONS

This laser tool is shipped with four (4) 1.5v AA alkaline batteries.

The Battery/Power Indicator **1b** blinks and turns off when batteries need replaced.

### INSERTING/REPLACING BATTERIES

Alkaline batteries are recommended for use to power this laser tool.



**Always replace all alkaline batteries at the same time. Only use batteries from one brand and with the identical capacity.**

**Remove the batteries from the tool when not using it for extended periods. When storing for extended periods, the batteries can corrode and discharge themselves.**

Open the battery compartment door **5** by pressing the latch release **6**.

When inserting batteries, pay attention to the correct polarity (+ and -) according to the representation on the

inside of the battery compartment.

Close the battery compartment door **5**. Push down until the door latch **6** clicks into the secure position.

**IMPORTANT** **Remove the batteries from the tool when not using it for extended periods.** When storing for extended periods, the batteries can corrode and discharge themselves.

## OPERATIONS

**WARNING** **Do not subject the laser tool to extreme temperatures or variations in temperature.** As an example, do not leave it in vehicles for long time. In case of large variations in temperature, allow the instrument to adjust to the ambient temperature before putting it into operation. In case of extreme temperatures or variations in temperature, the accuracy of the instrument can be impaired.

**Avoid heavy impact to or falling down of the instrument.** After severe exterior effects to the instrument, it is recommended to carry out an accuracy check each time before continuing to work.

**This laser tool is a precision instrument and should be treated with care.**

**IMPORTANT** When not in use, the Safety Lock/Automatic Leveling Switch **3** should always be in the  lock position.



This locks the pendulum and allows the laser to better withstand vibration and trauma incurred during transportation or if the unit is dropped.

## SETTING UP THE INSTRUMENT

Position the instrument on a firm surface, mount it to a tripod or to the multi-mount device. Due to

the leveling accuracy, the laser tool reacts sensitively to ground vibrations. Therefore, pay attention that the position of the instrument is stable in order to avoid operational interruptions due to re-leveling.



## POWER ON AND OFF

To Power ON the laser tool, slide the Safety Lock / Automatic Leveling Switch **3** to the  position.



Press the ON/OFF Power button  **1a** once to project laser beams in self-leveling mode.

The Operating Mode Indicator **1b** will illuminate green.

KS Model	Number of Laser Points	
<b>KS 3P</b>	3	
<b>KS 5P KS 5PG</b>	5	

# CHECK ACCURACY

The ambient temperature has the greatest influence on the accuracy.

The tool should be mounted on a tripod when using for distances exceeding 65-ft (20m).

If possible, set up the tool in the center of the work area.

Should the laser tool exceed the maximum deviation **d** during one of the following tests, Contact your local authorized Dave White's SitePro service center.

## Checking the Vertical Leveling Accuracy

Use an interior room with a measuring height of approximately 13 feet (4 m).

- Mount the laser tool onto a tripod or place it on a firm level surface approximately 3-ft (1m) preferably from floor. Switch ON laser tool.
- Position the laser tool in such a manner that the plumb up beam points against a line on the ceiling.
- Mark the center of the upper laser point on the line (point **1**). Then, mark the center of the laser point on the floor (point **2**).

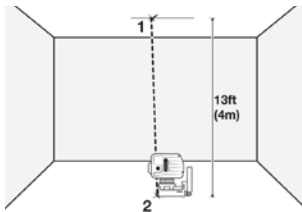

- Rotate the laser tool by 180° and position the plumb down laser beam directly on the mark on the floor (point **2**) and the upper laser point is directed against the line on the ceiling.
- Allow the tool to level in. Mark the center of the plumb up laser point on the line on the ceiling (point **3**).

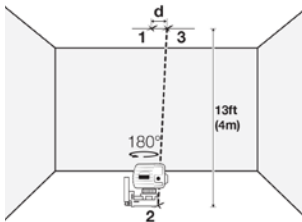

- The difference **d** of both marked points **1** and **3** on the ceiling results in the actual deviation of the tool to the plumb line.

- The difference **d** between points **1** and **3** should not exceed 1/8-inch (3 mm).

### Checking the Horizontal Leveling Accuracy of the Lateral Axis

Use an area with a distance of approximately 30 feet (10 m) to the wall is required.

- Mount the laser tool onto a tripod or place it on a firm level surface approximately 3-ft (1m) from floor. Switch ON laser tool.
- Direct the longitudinal or front laser beam at the wall. Allow the laser tool to level in.
- Mark the center point of the laser beam on the wall (point **A**).

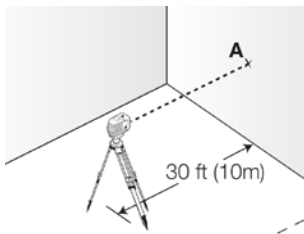

- Rotate the measuring tool 90°, allow it to level in.
- Mark the center point of the laser beam on the wall (point **B**).

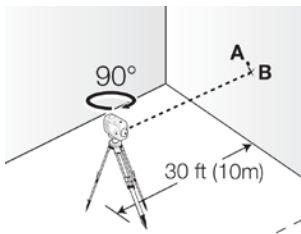

- Rotate the laser tool 180°, allow it to level in.
- Mark the center point of the laser beam on the wall (point **C**).

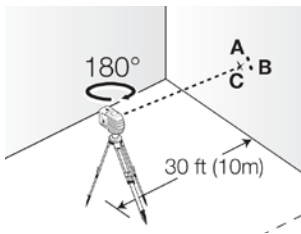

- The difference **d** of the highest point and the lowest point on the wall (example: point **A** and **C**) results in the actual deviation of the tool to the horizontal axis.



- The difference **d** between points **A** and **C** should not exceed 1/8-inch (3 mm).

### Checking the Horizontal Leveling Accuracy of the Longitudinal Axis

Use an area with a distance of approximately 16 feet (5 m) between two walls **A** and **B** is required.

- Mount the laser tool onto a tripod or place it on a firm level surface approximately 8-ft (2.5m) from wall **A**. Switch ON laser tool.
- Direct the longitudinal or front laser beam on wall **A**.
- Mark the center point of the laser beam on wall **A** (point **A1**).

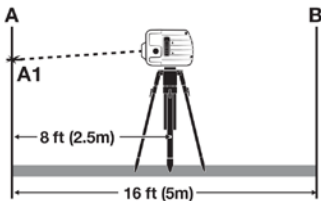

- Rotate the measuring tool 180°, allow it to level in.
- Mark the center point of the laser beam on wall **B** (point **B1**).

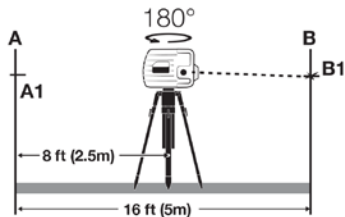

- Without turning the measuring tool, position it close to wall **A** (approximately 20-inches (0.5 m)). Switch the measuring tool on and allow it to level in.
- Mark the center point of the laser beam on wall **A** (point **A2**).

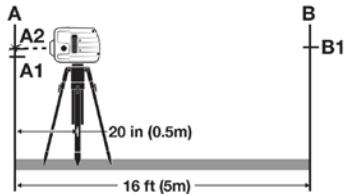

- Rotate the measuring tool 180°, allow it to level in.
- Mark the center point of the laser beam on wall **B** (point **B2**).

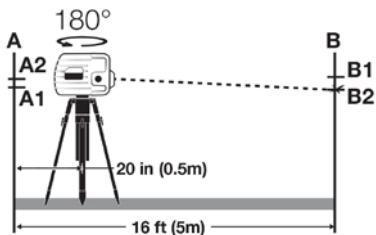

- The difference **d** of the marked points on wall **A** and **B** results in

the actual deviation of the laser tool horizontal leveling accuracy.

- The difference **d** is calculated using the following formula:

$$(A1 - B1) - (A2 - B2) = d$$

The maximum allowable deviation **d** is 1/8-in (3 mm).

# UMP1 MULTI-MOUNT DEVICE

The UMP1 versatile mounting device is used to mount the your KS laser tool virtually anywhere.

## UMP1 FEATURES AT A GLANCE

The numbering of the product features shown refers to the illustration of the tool on page 5.

1. 1/4-20 Thread Mounting Knob
2. Keyhole Mounting Slot
3. Magnets
4. Laser Alignment Knobs
5. Strap Mounting Slots
6. 1/4-20 Tripod Mount Thread
7. 5/8-11 Tripod Mount Thread

## HOW TO USE THE UM2S

The multi-mount device provides the easy ability to properly position the laser points. It mounts or attaches to most job site surfaces to aid in positioning the laser tool. The laser tool fastens to the locking mount knob **1** with 1/4-20 thread.

To fasten the laser tool on the Multi-Mount Device, screw the locking screw **1** of the Multi-Mount Device into the 1/4-20 Tripod Mounting Thread **8** on the laser tool and tighten.

To rotate the laser tool on the Multi-Mount Device, rotate using the mounting knob **1**.

With the Multi-Mount Device, the laser tool can be attached as follows:

- Fasten to a camera tripod via the 1/4" tripod mount thread **6**.
- Fasten to a construction tripod via the 5/8-11 tripod mount thread **7**.
- Fasten to steel studs or parts via the built-in magnets **3**.
- Fasten to drywall or wood walls with screw. Insert screw with a minimum length of 2-in into the keyhole mounting slot **2**.

Fasten to pipes or similar beams using a strap and threading it through the strap mounting slots **5**.

# MAINTENANCE AND SERVICE

**Store and transport the tool only in the supplied protective case.**

**Keep the tool clean at all times.**

**Do not immerse the tool into water or other fluids.**

**Wipe off debris using a moist and soft cloth.** Do not use any cleaning agents or solvents.

**Regularly clean the surfaces at the exit opening of the laser in particular, and pay attention to any fluff of fibers.**

If the tool should fail despite the care taken in manufacturing and testing procedures, repair should be carried out by an authorized after-sales service center for Dave White's SitePro instruments. In all correspondence and spare parts orders, please always include the

model number and serial number of the instruments.

**All precision instruments should be cleaned, lubricated, checked and adjusted ONLY at a qualified instrument repair station or by the manufacturer, at least once a year.**

**In case of repairs, send in the instrument packed in its protective case.**

## ENVIRONMENT PROTECTION

Recycle raw materials & batteries instead of disposing of waste.

The unit, accessories, packaging & used batteries should be sorted for environmentally friendly recycling in accordance with the latest regulations.



# LIMITED WARRANTY

Dave White's SitePro ("Seller") warrants to the original purchaser only, that KS-series laser tools will be free from defects in material or workmanship for a period of one (1) year from date of purchase.

SELLER'S SOLE OBLIGATION AND YOUR EXCLUSIVE REMEDY under this Limited Warranty and, to the extent permitted by law, any warranty or condition implied by law, shall be the repair or replacement of parts, without charge, which are defective in material or workmanship and which have not been misused, carelessly handled, or mis-repaired by persons other than Seller or an Authorized Service Center. To make a claim under this Limited Warranty, you must return the complete product, transportation prepaid, to any SitePro Authorized Service Center. Please include a dated proof of purchase with your tool. For locations of nearby service centers, e-mail us at [info@sitepro.us.com](mailto:info@sitepro.us.com) or call 1-855-354-9881.

THIS LIMITED WARRANTY DOES NOT APPLY TO ACCESSORY ITEMS SUCH AS TRIPODS, RODS, HAND LEVELS, FIELD SUPPLIES, TAPES, MOUNTING DEVICES AND OTHER RELATED ITEMS. THESE ITEMS RECEIVE A 90 DAY LIMITED WARRANTY.

All rotary lasers and optical instruments will be free from defects in material or workmanship for a period of two (2) years from date of purchase.

ANY IMPLIED WARRANTIES SHALL BE LIMITED IN DURATION TO ONE YEAR FROM DATE OF PURCHASE. SOME STATES IN THE U.S., AND SOME CANADIAN PROVINCES DO NOT ALLOW LIMITATIONS ON HOW LONG AN IMPLIED WARRANTY LASTS, SO THE ABOVE LIMITATION MAY NOT APPLY TO YOU.

IN NO EVENT SHALL SELLER BE LIABLE FOR ANY INCIDENTAL OR CONSEQUENTIAL DAMAGES (INCLUDING BUT NOT LIMITED TO LIABILITY FOR LOSS OF PROFITS) ARISING FROM THE SALE OR USE OF THIS PRODUCT. SOME STATES IN THE U.S., AND SOME CANADIAN PROVINCES DO NOT ALLOW THE EXCLUSION OR LIMITATION OF INCIDENTAL OR CONSEQUENTIAL DAMAGES, SO THE ABOVE LIMITATION MAY NOT APPLY TO YOU.

THIS LIMITED WARRANTY GIVES YOU SPECIFIC LEGAL RIGHTS, AND YOU MAY ALSO HAVE OTHER RIGHTS WHICH VARY FROM STATE TO STATE IN THE U.S., OR PROVINCE TO PROVINCE IN CANADA AND FROM COUNTRY TO COUNTRY.

THIS LIMITED WARRANTY APPLIES ONLY TO PRODUCTS SOLD WITHIN THE UNITED STATES OF AMERICA, CANADA AND THE COMMONWEALTH OF PUERTO RICO. FOR WARRANTY COVERAGE WITHIN OTHER COUNTRIES, CONTACT YOUR LOCAL SITEPRO DEALER OR IMPORTER.

# TECHNICAL DATA



	<b>KS 3P</b>	<b>KS 5P</b>	<b>KS 5PG</b>
<b>Accuracy</b>	± 1/8-in at 30 ft (± 3 mm at 10 m)	± 1/8-in at 30 ft (± 3 mm at 10 m)	± 1/8-in at 30 ft (± 3 mm at 10 m)
<b>Leveling</b>			
Leveling Type	Self-Leveling	Self-Leveling	Self-Leveling
Compensation	Magnetic Dampening with Lock Switch	Magnetic Dampening with Lock Switch	Magnetic Dampening with Lock Switch
Leveling Range	± 6°	± 6°	± 6°
<b>Beam</b>	Red	Red	Green
Number of Beams	3	5	5
Laser Diode	635 nm <1mW	635 nm <1mW	520-540 nm <1mW
Laser Hazard Class	Hazard Class 2	Hazard Class 2	Hazard Class 2
<b>Operating Range</b>	100 ft (30 m) dependent on illumination of work area	100 ft (30 m) dependent on illumination of work area	100 ft (30 m) dependent on illumination of work area
<b>Environment</b>	+14° F to 113° F (-10° C to 45° C)	+14° F to 113° F (-10° C to 45° C)	+14° F to 113° F (-10° C to 45° C)
<b>Power Source</b>	Four (4) AA Alkaline Batteries	Four (4) AA Alkaline Batteries	Four (4) AA Alkaline Batteries
Run Time (typical)	20+ hrs of continuous use	20+ hrs of continuous use	20+ hrs of continuous use
<b>Dimension</b>	4.13 x 1.65 x 2.95" (105 x 42 x 75 mm)	4.13 x 1.65 x 2.95" (105 x 42 x 75 mm)	4.13 x 1.65 x 2.95" (105 x 42 x 75 mm)
<b>Weight</b> (no batteries)	0.6 lb (0.27 g)	0.6 lb (0.27 g)	0.6 lb (0.27 g)

# IMPORTANT SAFETY INSTRUCTIONS



Read all instructions.

Failure to follow all instructions listed below may result in hazardous radiation exposure, electric shock, fire and/or serious injury.

**All labels on your laser are for your safety and must not be removed.**

Removing labels increases the risk of exposure to laser radiation. Do not throw this manual away.

**If glass light house breaks when dropped, contact customer service immediately.** Broken glass can cause laceration hazard and unit to lose its IP rating.



**DO NOT direct the laser beam at persons or animals and do not stare into the laser beam yourself.** This tool produces laser class 2 laser radiation and complies with 21 CFR 1040.10 and 1040.11 except for deviations pursuant to Laser Notice No. 50, dated June 24, 2007. This can lead to persons being blinded.

**DO NOT remove or deface any warning or caution labels.** Removing labels increases the risk of exposure to laser radiation.

**Use of controls or adjustments or performance of procedures other than**

**those specified in this manual, may result in hazardous radiation exposure.**

**ALWAYS make sure that any bystanders in the vicinity of use are made aware of the dangers of looking directly into the laser tool.**

**DO NOT place the laser tool in a position that may cause anyone to stare into the laser beam intentionally or unintentionally.** Serious eye injury could result.

**ALWAYS position the laser tool securely.** Damage to the laser tool and/or serious injury to the user could result if the laser tool falls.

**ALWAYS use only the accessories that are recommended by the manufacturer of laser tool.** Use of accessories that have been designed for use with other laser tools could result in serious injury or unsatisfactory performance.

**DO NOT use this laser tool for any purpose other than those outlined in this manual.** This could result in serious injury or unsatisfactory performance.

**DO NOT leave the laser tool “ON” unattended in any operating mode.**

**DO NOT disassemble the laser tool.** There are no user serviceable parts inside. Do not modify the product in

any way. Modifying the laser tool may result in hazardous laser radiation exposure.

## **WORK AREA SAFETY**

**Keep work area clean and well lit. Cluttered or dark areas invite accidents.**

**DO NOT operate the laser tool around children or allow children to operate the laser tool.** Serious eye injury could result.

**DO NOT use instruments, attachments and accessories outdoors when lightening conditions are present.**

## **ELECTRICAL SAFETY**

**Batteries can explode or leak, cause injury or fire. To reduce this risk, always follow all instructions and warnings on the battery label and package.**

**Remove the batteries from the tool when not using it for extended periods.** When storing for extended periods, the batteries can corrode and discharge themselves.

**DO NOT short any battery terminals.**

**DO NOT charge alkaline batteries.**

**DO NOT mix old and new batteries.**

**Replace all old batteries at the same time with new batteries of the same brand and type.**

**DO NOT mix battery chemistries.**

**Dispose of or recycle batteries per local code.**

**DO NOT dispose of batteries in fire. Keep batteries out of reach of children.**

## **PERSONAL SAFETY**

**Stay alert, watch what you are doing and use common sense when operating a tool. Do not use a tool while you are tired or under the influence of drugs, alcohol or medication.** A moment of inattention while operating a tool may result in serious personal injury or incorrect measurement results.

**Use safety equipment. Always wear eye protection.** Safety equipment such as dust mask, non-skid safety shoes, hard hat, or hearing protection used for appropriate conditions will reduce personal injuries.

**DO NOT use the laser viewing glasses as safety goggles.** The laser viewing glasses are used for improved visualization of the laser beam, but they do not protect against laser radiation.

**DO NOT use the laser viewing glasses as sun glasses or in traffic.** The laser viewing glasses do not afford complete UV protection and reduce color perception.

**DO NOT use any optical tools such as, but not limited to, telescopes or transits**

to view the laser beam. Serious eye injury could result.

**DO NOT stare directly at the laser beam or project the laser beam directly into the eyes of others.** Serious eye injury could result.

**Use caution when using instruments in the vicinity of electrical hazards.**

## MAGNETS



**Keep the tool, universal mount, and laser target away from cardiac pacemakers.** The

magnets of the tool and laser target plate generate a field that can impair the function of cardiac pacemakers.

**Keep the tool and laser target away from magnetic data medium and magnetically-sensitive equipment.**

**The effect of the magnets of the tool and laser target plate can lead to irreversible data loss.**

## USE AND CARE

**Use the correct tool for your application.** The correct tool will do the job better and safer.

**Do not use the tool if the switch does not turn it on and off.** Any tool that cannot be controlled with the switch is dangerous and must be repaired.

**Store idle tool out of the reach of children and do not allow persons unfamiliar with the tool or these instructions to operate the tool.**

**Tools are dangerous in the hands of untrained users.**

**Maintain tools. Check for misalignment or binding of moving parts, breakage of parts and any other condition that may affect the operation.** If damaged, repair tool before use. Many accidents are caused by poorly maintained tools.

**Use the tool, accessories, etc., in accordance with these instructions and in the manner intended for the particular type of tool, taking into account the working conditions and the work to be performed.** Use of the tool for operations different from those intended could result in a hazardous situation.

**SAVE THESE INSTRUCTIONS.**



©2017 Dave White's SitePro LLC  
Lafayette, IN USA

[www.dwsitepro.com](http://www.dwsitepro.com)

PHONE  
**+1 (765) 581-4097**

TOLL FREE (US ONLY)  
**(855) 354-9881**

EMAIL  
**[info@dwsitepro.com](mailto:info@dwsitepro.com)**

© 2020 copyright Dave White's SitePro LLC. All rights reserved.  
SitePro and the Aperture & D W logo are trademarks of Dave White's SitePro LLC, in the United States and in other countries. All other trademarks are the property of their respective owners. Design and specification of products are subject to change without notice.